

Operation: 敏感型

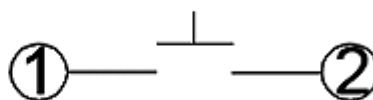

LTEM NO.:TS-1104-
(6.0x6.0 TACTILE-SWITCH)

Unit:mm

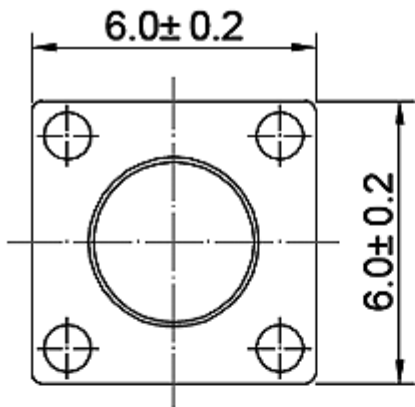

M	H
3.4	4.3
3.4	5.5
3.4	5.0
3.3	6.0
	9.5
3.0	10.0
	16.0

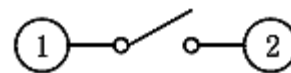
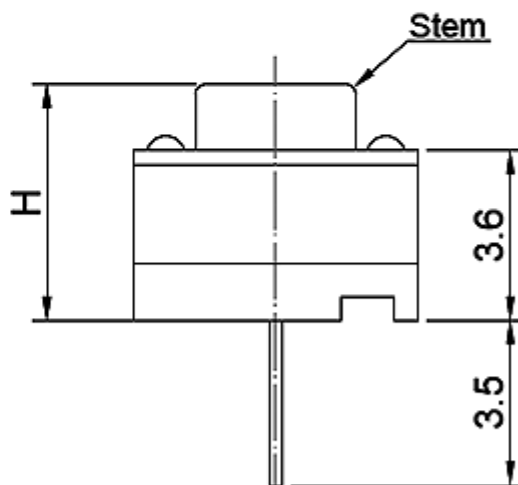
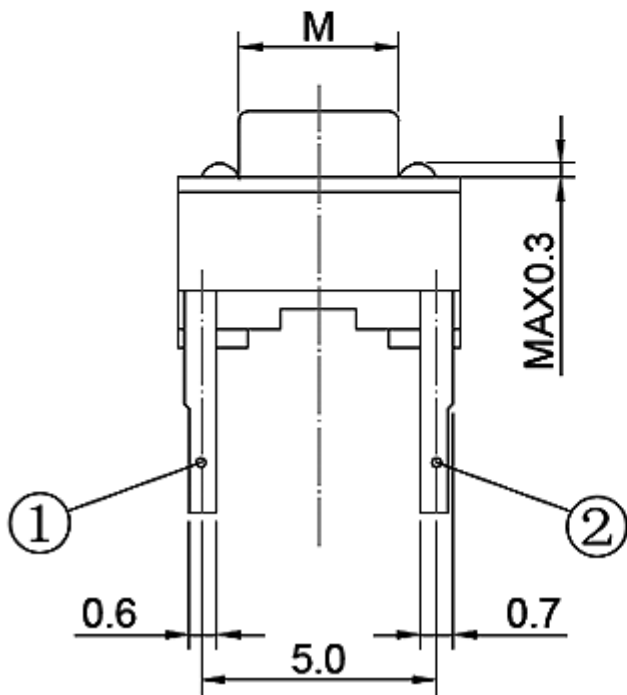

Technical parameter

PROJECT		LEVEL	A[better product]	B[average product]	C[low product]
Electrical Properties	Initial Contact Resistance		30mΩ max.	30mΩ max.	no data!
	Contact Resistance		100mΩ min.100V DC Skey/PD: 50mΩ min.100V DC		
	Withstand Voltage		300V AC for 1min	250 V AC for 1min	
Durable Performance	There No Load		150,000 Cycles	120,000 Cycles	no data!
	Rated Load		120,000 Cycles 50mΩ max.	100,000 Cycles 30mΩ max.	no data!
Insertion Force			4.0Kgf MAX (Springback:)		

表面貼裝 SMT

側向導入 LATERAL

精密部品 NICETY

可靠 STABILIZE

適合環保 RoHS

CIRCUIT BOARD SIZE
(Vertical view)

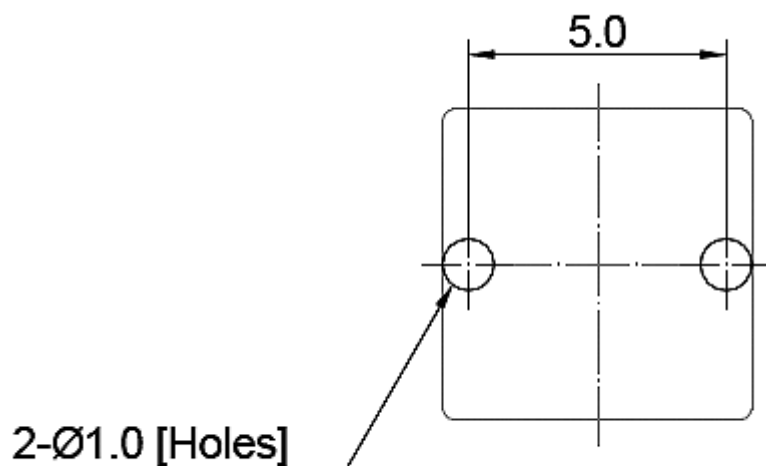

項目		等級		
		A 级[产品]	B 级[产品]	C 级[产品]
机械性能	端子强度	3N for 1 min.	2N for 1min.	
	操作强度	工作方向	100gf±0.3N. 160gf±0.3N. 250gf±0.3N. 2N(200grams)	
		拉引方向	100gf [20gf]	160gf [30gf]

PIN Assignment

Material declaration

No.	NAME	Type	Description
①	主軸	1	PA46(热塑性塑胶)黑
②	基座	1	LCP(黑-端子镀银)
③	上盖	1	不锈钢
④	弹片	1	覆银不锈钢(镀银)

本品不屬於危害性廢棄物,須丟棄時可以委託回收商予以回收再生處理。Products do not belong to hazardous waste,When waste can recycling processing

運送時本產品不要直接與水、酸鹼性化學物質接觸,或放置於含有以上氣體環境中,並且需要注意會有滑落、側翻的危險發生;運輸過程中不能有碰撞或者擠壓,須保證溫度與濕度適中[常溫 25°C,濕度在 50°C 以內],不可導致材料變形或氧化。

注記 NOTICE

1. 碩方電子公司擁有最終解釋權; The company reserves the right of final interpretation;
2. 文件禁止外洩、轉載; Leaked and reproduced prohibited;
3. 未經授權修改無效。Modify is invalid.